

Translations, Reflections, and Rotations

The Marching Cougars Tigers Lesson 9-1 Transformations

ACTIVITY 9

Learning Targets:

- Perform transformations on and off the coordinate plane.
- Identify characteristics of transformations that are rigid motions and characteristics of transformations that are non-rigid motions.
- Represent a transformation as a function using coordinates, and show how a figure is transformed by a function.

SUGGESTED LEARNING STRATEGIES: Debriefing, Think-Pair-Share, Predict and Confirm, Self Revision/Peer Revision

Mr. Scott directs the Marching Cougars, the band at Chavez High School. He uses the coordinate plane to represent the football field. For the band's first show, he arranges the band in a rectangle that is 6 marchers wide and 9 marchers deep.

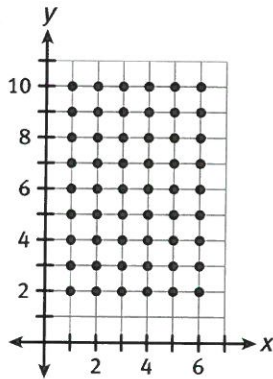

The band begins by marching down the grid in this formation. Then the marchers move apart from each other vertically, while keeping the same distance between marchers within the same row.

The diagrams on the next page show the initial shape of the marchers, and the two **transformations** that they undergo. To describe and classify the transformations, compare the **pre-image** of a transformation to its **image**.

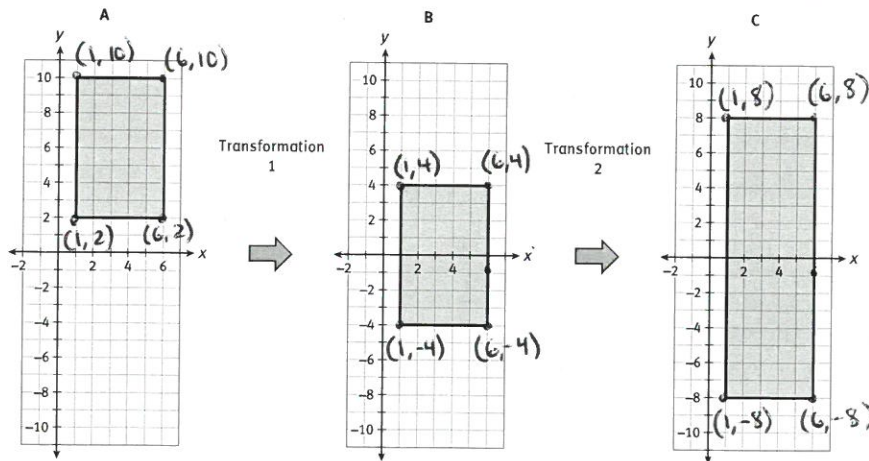

1. Use your own words to describe Transformation 1.

The transformation is a slide or movement down the coordinate grid.

My Notes

DISCUSSION GROUP TIPS

As you work in groups, read the problem scenario carefully and explore together the information provided. Discuss your understanding of the problem and ask peers or your teacher to clarify any areas that are not clear.

MATH TERMS

A **transformation** is a change in the position, size, or shape of a figure.

The **pre-image** of the transformation is the original figure. The **image** is the figure after the transformation.

An image often has prime markers (') next to its points. With each successive transformation, another prime marker is added. "p" = "p prime"

My Notes

MATH TERMS

A **rigid motion** is a transformation that preserves size and shape.

TECHNOLOGY TIP

You can also use geometry software to represent transformations, including rigid motions and non-rigid motions.

READING IN MATH

The arrow (\rightarrow) in the notation that shows how a point is transformed means "goes to."

2. Compare Transformation 1 and Transformation 2. How do the two transformations compare?

The first transformation preserves the size and shape of the rectangle. The second expands or stretches the size in a vertical direction.

3. **Model with mathematics.** Transformation 1 is an example of a **rigid motion**. A rigid motion keeps the same distance between the points that are transformed (in this situation, the marchers of the band); the shape and size of the pre-image and image are the same.

- a. How does Transformation 1 affect the distance between any two marchers in the band?

The distance between any two marchers remains the same.

- b. How does Transformation 2 affect the distance between the marchers? Is Transformation 2 a rigid motion?

Transformation 2 preserves the distance between the marchers in a row, but increases the distance between marchers in different rows. It is not a rigid motion.

4. Review Transformation 1. Each point in the pre-image is mapped to a point in the image. For this reason, the transformation can be expressed as a function.

- a. Complete the table to show the positions of the four corners of the rectangle when Figure A is mapped onto Figure B.

Figure A (pre-image)	Figure B (image)
upper left (1, 10)	(1, 4)
lower left (1, 2)	(1, -4)
upper right (6, 10)	(6, 4)
lower right (6, 2)	(6, -4)

- b. For any given point, how does the transformation change the x -coordinate and y -coordinate?

The x -coordinate stays the same. The y -coordinate decreases by 6.

- c. You can use the notation $(1, 10) \rightarrow (1, 4)$ to show how a point is transformed. When you use this notation to show how a general point (x, y) is transformed, you are expressing the transformation as a function. Express Transformation 1 as a function.

$$(x, y) \rightarrow (x, y - 6)$$

Lesson 9-1
Transformations

ACTIVITY 9

continued

My Notes

5. Review Transformation 2.
a. Complete the table to show the positions of the four corners of the rectangle when Figure B is mapped onto Figure C.

Figure B (pre-image)	Figure C (image)
upper left (1, 4)	(1, 8)
lower left (1, -4)	(1, -8)
upper right (6, 4)	(6, 8)
lower right (6, -4)	(6, -8)

- b. For any given point, how does the transformation change the x -coordinate and y -coordinate?

The x -coordinate remains the same. The y -coordinate is multiplied by 2.

- c. Can Transformation 2 also be expressed as a function? Explain why or why not. Write the function if it exists.

Yes. It is non-rigid.

$$(x, y) \rightarrow (x, 2y)$$

6. Draw each image on the graph to show how the pre-image is transformed by the function. Then classify the transformation as rigid or non-rigid.

- a. $(x, y) \rightarrow (x + 3, y)$ rigid
(3 units to the right)

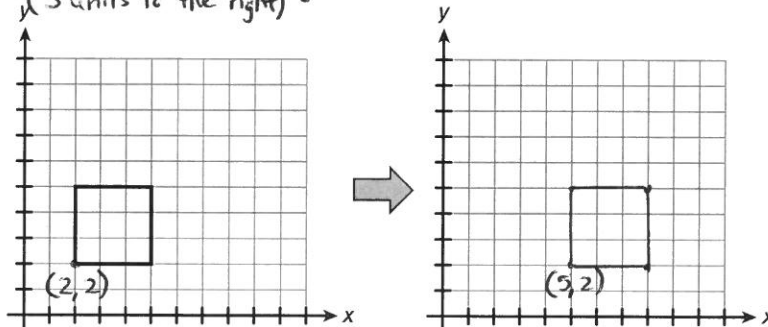

- b. $(x, y) \rightarrow (2x, 2y)$ non-rigid

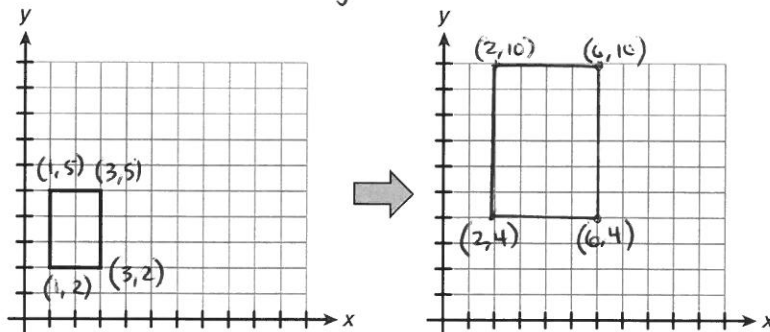

7. Write the numeral "4" in the middle of each pre-image in Item 6. Describe how the numeral should appear in each image.

In 6a, same size and shape

In 6b, same shape but linear dimensions are twice as large.

CONNECT TO ALGEBRA

You've used functions extensively in algebra. Recall that a function is a set of ordered pairs in which each x -value is associated with one, and only one, y -value.

DISCUSSION GROUP TIPS

As you read and discuss the transformations, ask and answer questions to be sure you have a clear understanding of not only all the terminology used, but also the link between the algebraic notation and the graphs.

rigid \rightarrow use addition and/or subtraction

non-rigid \rightarrow use multiplication and/or division

My Notes

Check Your Understanding

Use the text and diagram to answer Items 8 and 9.

The rectangle undergoes the transformation described by the function $(x, y) \rightarrow (x - 2, y + 1)$.

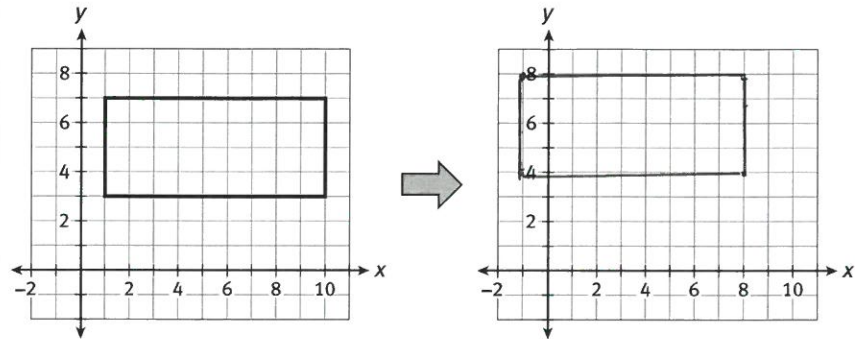

8. Complete the table to show the coordinates of the image and pre-image for the four corners of the rectangle.

Pre-image	Image
(1, 3)	(-1, 4)
(1, 7)	(-1, 8)
(10, 7)	(8, 8)
(10, 3)	(8, 4)

9. Graph the transformation of the figure. Is the transformation a rigid motion or non-rigid motion? Explain how you know.
10. A rectangle is transformed as shown.

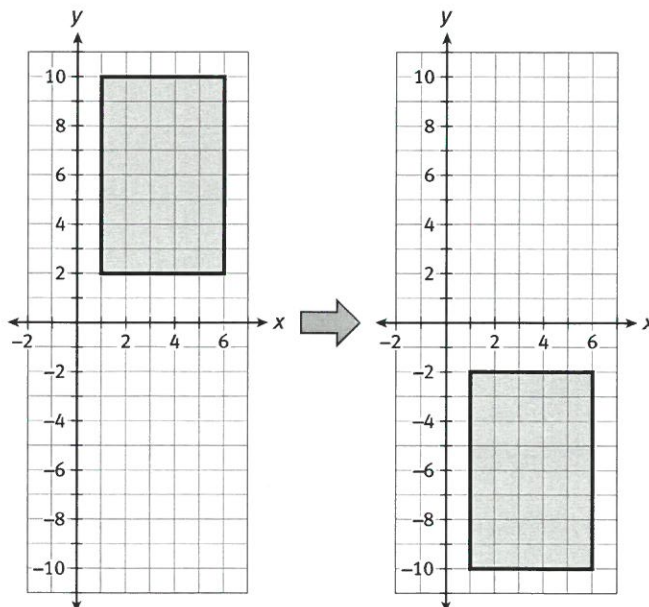

MATH TIP

A rigid motion can be modeled by sliding, rotating, or flipping a figure. A non-rigid motion often involves stretching or compressing the figure.

9) Rigid motion. The image has the same size and shape as the pre-image.

10a) $(x, y) \rightarrow (x, y - 12)$

10b) Rigid. The image has the same size and shape as the pre-image.

Lesson 9-1 Transformations

ACTIVITY 9

continued

- Which function describes the transformation?
- Classify the transformation as rigid or non-rigid. Explain why you classified the transformation that way.

LESSON 9-1 PRACTICE

For Items 11 and 12, consider the following: A rectangle undergoes the transformation described by the function $(x, y) \rightarrow \left(x, \frac{y}{2}\right)$.

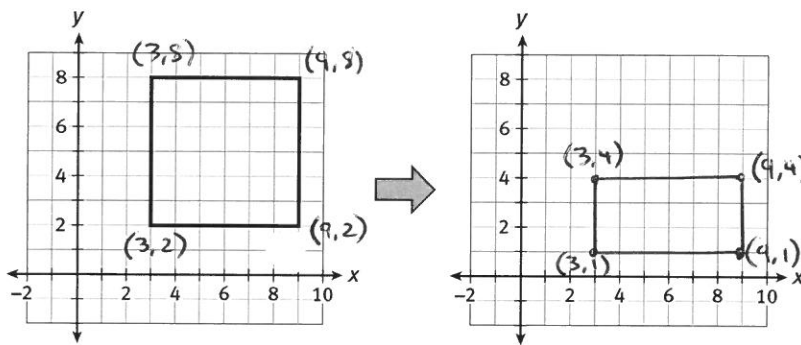

- Graph the transformation of the figure. Is the transformation a rigid motion? Explain.
- Reason abstractly.** Draw a plus sign (+) in the middle of the image. Describe how the transformation would change the plus sign.
- Attend to precision.** Use the graph of the rectangle to help you classify each of the following transformations.
 - Draw the image of the rectangle under the transformation described by the function $(x, y) \rightarrow \left(\frac{x}{2}, y\right)$. Classify the transformation as rigid or non-rigid.
 - Draw the image of the rectangle under the transformation described by the function $(x, y) \rightarrow (x, y + 2)$. Classify the transformation as rigid or non-rigid.

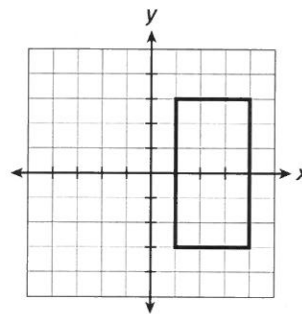

MATH TIP

Many different transformations can transform a pre-image to the same image. Consider sliding, flipping, and turning.

11) No. The image is smaller than the pre-image.

12) The horizontal line in the plus sign would remain the same length, while the vertical line becomes shorter.

13a) non-rigid

13b) rigid

My Notes

Learning Targets:

- Perform translations on and off the coordinate plane.
- Predict the effect of a translation on a figure.

SUGGESTED LEARNING STRATEGIES: Visualization, Create Representations, Predict and Confirm, Think-Pair-Share

Maria marches with the band. At the start of the halftime show, her position is $(2, 4)$ on the coordinate plane. Then Mr. Scott tells everyone to move 2 yards to the right on the field and 4 yards up the field. The band's transformation is shown in the diagram, and Maria's position is marked with an X.

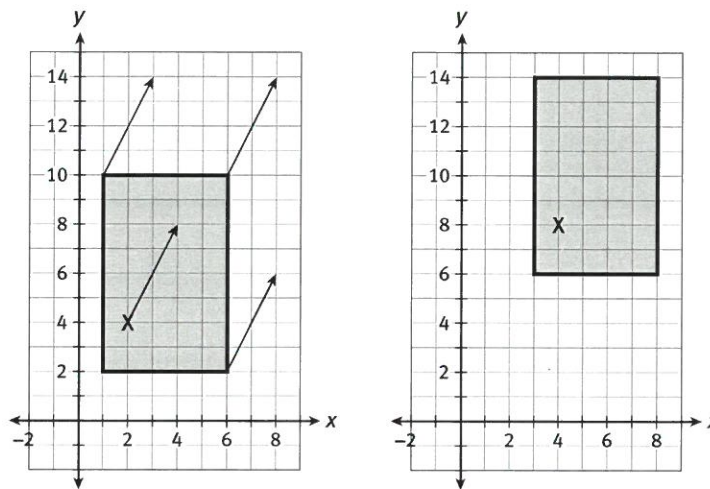

MATH TERMS

A **translation** is a rigid motion in which every point is moved the same distance and in the same direction.

A **directed line segment** is the distance and direction of the translation.

This type of transformation is called a **translation**. On the coordinate plane, a translation is described by a function of the form $(x, y) \rightarrow (x + a, y + b)$, in which a and b are positive or negative constants. In the example above, $a = 2$ and $b = 4$.

You can think of a translation as a figure sliding up or down, left or right, or diagonally. During the translation, every point of the figure moves the same distance and in the same direction. This distance and direction is called a **directed line segment**. In the diagram, the directed line segment of the translation is shown by each of the arrows.

1. Complete the table to show how the translation affects four of the Marching Cougars.

Marcher	Pre-image	Image
Maria	$(2, 4)$	$(4, 8)$
Joe	$(3, 7)$	$(5, 11)$
Alfredo	$(1, 8)$	$(3, 12)$
LeJaya	$(5, 7)$	$(7, 11)$

Lesson 9-2

Translations

ACTIVITY 9

continued

Mr. Scott arranges the band in a rectangle. Then he directs the band member at (6, 10) to move to (4, 13). The numbers on the coordinate plane show yards of the football field.

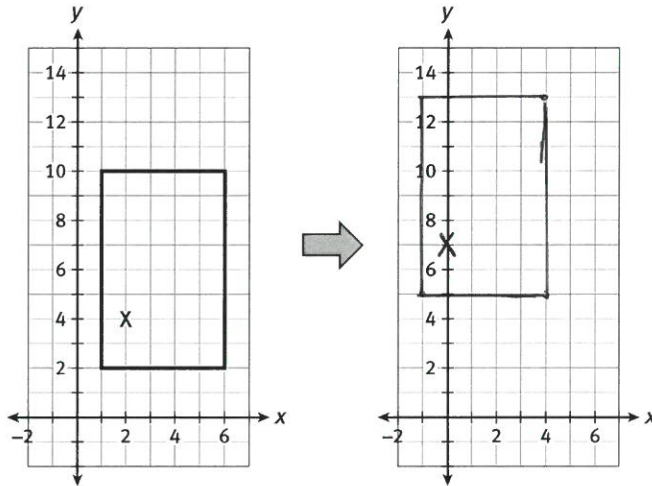

2. For the band to move in a translation, how should each band member move?

2 yards to the left and 3 yards up

3. **Critique the reasoning of others.** Maria was positioned at point (2, 4). Her friend tells her that Maria's new position is described by the function $(x + 3, y - 2)$ since her new position is (7, 0). Is her friend correct? Explain.

No. Her new position is $(2+3, 4-2) = (5, 2)$

MATH TIP

A translation always preserves the length and width of a figure.

Check Your Understanding

Draw the image of the figure under the translation described by the function.

4. $(x, y) \rightarrow (x + 4, y - 4)$

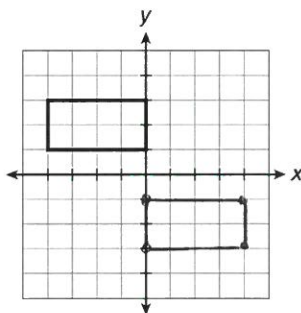

5. $(x, y) \rightarrow (x + 3, y)$

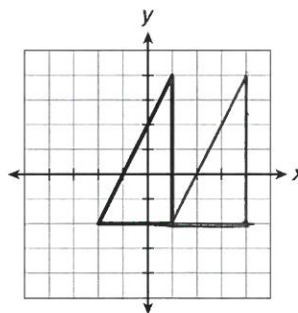

My Notes

MATH TERMS

A **rhombus** is a parallelogram with four congruent sides.

What does $T_{\overline{AB}}(P)$ mean?

T = translation

\overline{AB} indicates the length of the translation. The translation will be parallel to \overline{AB} . Each point will move in the direction that it would move to go from point A to point B.

Translations can also be defined without the coordinate plane. For the directed line segment \overline{AB} , a translation maps point P to point P' so that the following statements are true:

- $\overline{PP'}$ is parallel to \overline{AB}
- $PP' = AB$
- $\overline{PP'}$ is in the same direction as \overline{AB} .

The expression $T_{\overline{AB}}(P)$ describes the translation of a given point P by the directed line segment \overline{AB} . In the above example, $T_{\overline{AB}}(P) = P'$.

Items 6 through 8 refer to **rhombus** $ABCD$ shown below. Point P is in the center of the rhombus.

↳ a parallelogram with four congruent sides

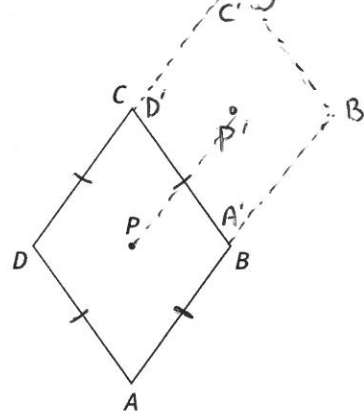

$$\overline{PP'} \cong \overline{AB}$$

$$\overline{PP'} \parallel \overline{AB}$$

6. Draw the translation of the rhombus described by directed line segment $\overline{AB'}$. Include $P' = T_{\overline{AB'}}(P)$.

→ match coordinates

7. Which part of the rhombus maps onto \overline{BC} ?
 \overline{AD} maps onto \overline{BC}

8. Identify a translation of the rhombus that would map exactly one point of the rhombus onto another point of the rhombus.

Sample answers: $T_{\overline{CA}}$ and $T_{\overline{AC}}$

9. Draw the following translations. Show the pre-image and image, and label corresponding points in each.

- square $ABCD$, translated four inches to the right
- right triangle ABC , translated three inches up
- right triangle ABC , translated by $T_{\overline{AB}}$

Lesson 9-2 Translations

ACTIVITY 9

continued

Check Your Understanding

10. Mr. Scott arranges the band in the shape of triangle ABC , shown below. Point P is in the interior of the triangle. He plans three transformations of the triangle, in which point P is mapped onto P' , P'' , and P''' , respectively.

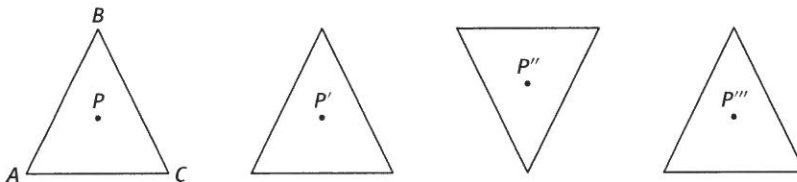

- Which of the three transformations are translations? Explain your answer by applying the definition of a translation.
- Maria stands at point P of triangle ABC . To move to point P' , her instructions are to move eight steps to the right. Do these instructions apply to all the other band members? Explain.

LESSON 9-2 PRACTICE

The figure shows hexagon $ABCDEF$ undergoing a translation to the right.

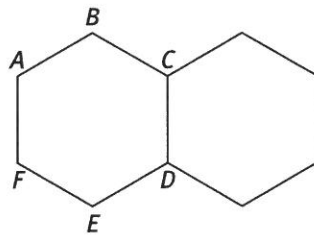

- Which part of the pre-image is translated onto \overline{CD} ?
- Express the translation as a function of two points of the hexagon.
- Make use of structure.** By applying this translation many times, you could create a row of hexagons. What additional translation could be repeated to fill the page with hexagons? Is it $T_{\overline{BC}}$, $T_{\overline{BD}}$, or $T_{\overline{BE}}$?

tessellation

My Notes

10a) The transformations that map P onto P' and P''' are translations.

10b) Yes, because all points map according to the same directed line segment, which is $\overline{PP'}$.

TECHNOLOGY TIP

You can use drawing or painting software to model translations. First draw a figure, then make a copy of it, and then drag the copy of the figure anywhere on the screen. No matter where you place the copy, you have created a translation of the original figure. Try the translation of the hexagon described here.

1) \overline{AF} is translated onto \overline{CD} .

2) $T_{\overline{AC}}$ or $T_{\overline{FD}}$

3) $T_{\overline{BD}}$

My Notes

Reflection rules

Across the x -axis

$$(x, y) \rightarrow (x, -y)$$

Across the y -axis

$$(x, y) \rightarrow (-x, y)$$

Across the line $y = x$

$$(x, y) \rightarrow (y, x)$$

Across the line $y = -x$

$$(x, y) \rightarrow (-y, -x)$$

Learning Targets:

- Perform reflections on and off the coordinate plane.
- Identify reflectional symmetry in plane figures.

SUGGESTED LEARNING STRATEGIES: Visualization, Create Representations, Predict and Confirm, Think-Pair-Share

Mr. Scott plans another transformation for the Marching Cougars. The sign of the y -coordinate of each marcher changes from positive to negative. Maria, whose position is shown by the X in the diagram, moves from point $(2, 4)$ to point $(2, -4)$.

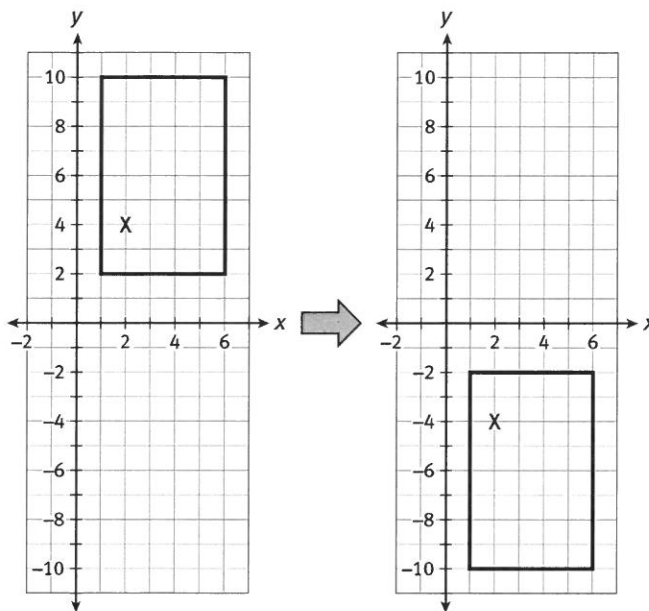

This type of transformation is called a **reflection**. Reflections are sometimes called flips because the figure is flipped like a pancake. On the coordinate plane, examples of reflections are defined by the functions $(x, y) \rightarrow (-x, y)$, which is a reflection across the y -axis. The example shown above is described by $(x, y) \rightarrow (x, -y)$, which is a reflection across the x -axis. The function $(x, y) \rightarrow (y, x)$ defines a reflection across the line $y = x$.

Every reflection has a **line of reflection**, which is the line that the reflection maps to itself. In the above diagram, the line of reflection is the x -axis.

1. Complete the table for the two reflections.

Pre-image	Image $(x, y) \rightarrow (x, -y)$	Image $(x, y) \rightarrow (-x, y)$
$(1, 10)$	$(1, -10)$	$(-1, 10)$
$(6, 10)$	$(6, -10)$	$(-6, 10)$
$(1, 2)$	$(1, -2)$	$(-1, 2)$
$(6, 2)$	$(6, -2)$	$(-6, 2)$

Lesson 9-3
Reflection

ACTIVITY 9

continued

The figure shows an arrow in the coordinate plane. The tip of the arrow is located at point (4, 10).

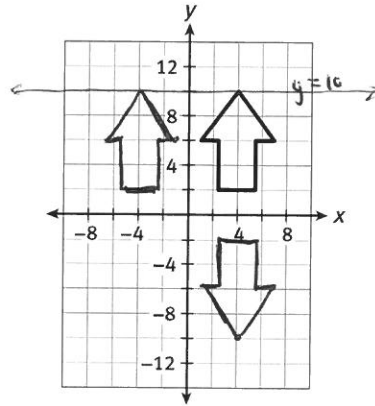

2. Predict the direction of the arrow after these reflections:

- a. across the x -axis *downward*
- b. across the y -axis *upward*

3. Draw the two reflections. Were your predictions correct?

4. What reflection maps the arrow to a downward arrow that also has its tip at the point (4, 10)?

a reflection across the line $y=10$

5. Could a reflection map the arrow so it points to the right or to the left (i.e., parallel to the x -axis)? If yes, describe the line of reflection.

Yes. The line of reflection would have to have a slope of 1 (point to the right) or a slope of -1 (point to the left).

My Notes

ACTIVITY 9

continued

Lesson 9-3 Reflection

My Notes

MATH TIP

Cut out paper shapes to model transformations. To show a reflection, flip the shape across the line of reflection.

Mr. Scott arranges the tuba players in an arrow formation, shown below. Then the tuba players undergo a reflection that is described by the function $(x, y) \rightarrow (8 - x, y)$.

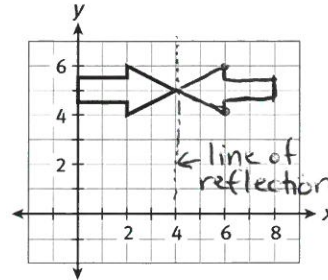

NOTES: Points on the line of reflection do not change position.

A point and its image can be connected by a segment that is perpendicular to the line of reflection.

A point and its image are equidistant from the line of reflection.

6. Draw the reflection. Identify the line of reflection.
the line of reflection is $x=4$

7. Which tuba players travel the longest distance during the reflection? Identify this distance.
The tuba players along the y-axis travel the longest distance, which is 8 units.

8. Which tuba player does not travel any distance during the reflection?
The tuba player at the point $(4, 5)$ does not change position.

9. Explain why the reflection does not change the distance between any given tuba player and the point $(4, 5)$.

A reflection preserves the size and shape of a figure, and thus preserves the distances between the points within the figure. Because the reflection maps $(4, 5)$ to itself, the reflection will preserve the distance from each tuba player to $(4, 5)$.

Lesson 9-3
Reflection

ACTIVITY 9

continued

- 10. Use appropriate tools strategically.** Use geometry software to explore reflections. First, use the software to draw a pentagon. Then draw a line of reflection that passes through one side of the pentagon. Use the software to reflect the pentagon over this line of reflection.

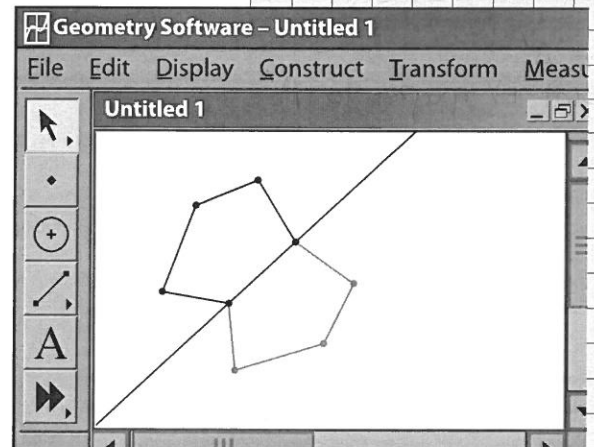
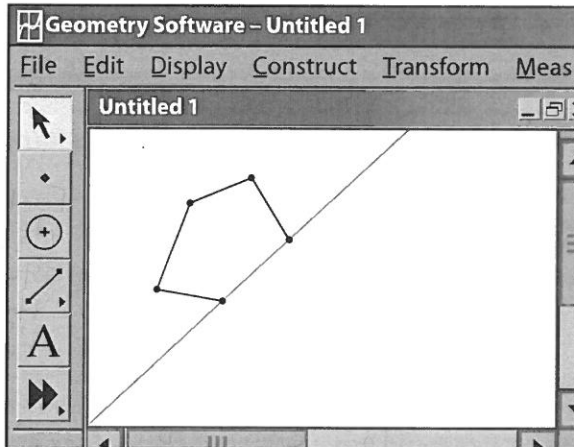

- 11.** What happens under this reflection to points that lie on the line of reflection?

These points do not move under the reflection. The image of each of these points is the same as the pre-image.

- 12.** Use the software to explore how a point not on the line of reflection is related to its image.

- a.** Measure the distance of a point to the line of reflection. Then measure the distance of the point's image to the line of reflection. What do you find?

A point and its image are the same distance from the line of reflection.

- b.** Draw the segment that connects a point and its image. How is this segment related to the line of reflection?

The segment is perpendicular to the line of reflection.

ACTIVITY 9

continued

Lesson 9-3 Reflection

My Notes

r_ℓ = reflection over line ℓ as the line of reflection

$r_\ell(A) = A'$
Point A maps to A'

Like other transformations, reflections can be defined independently of the coordinate plane. A **reflection** is a transformation that maps P to P' across line ℓ such that:

- If P is not on ℓ , then ℓ is the perpendicular bisector of $\overline{PP'}$.
- If P is on ℓ , then $P = P'$.

To describe reflections, we will use the notation $r_\ell(P) = P'$, in which r_ℓ is the function that maps point P to point P' across line ℓ , the line of reflection.

13. The diagram shows pentagon $ABCDE$ and the reflection r_ℓ .

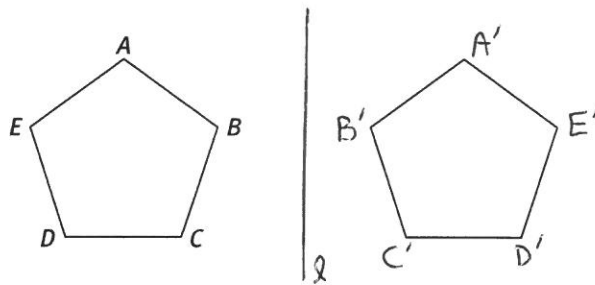

Each point and its image are equidistant from the line of reflection.

- Draw line ℓ .
 - Label the points $r_\ell(A) = A'$, $r_\ell(B) = B'$, and so on for the five vertices.
14. Quadrilateral $ABDC$ was constructed by drawing scalene triangle ABC , then drawing its reflection across line BC . Point P is the intersection of BC and AD .

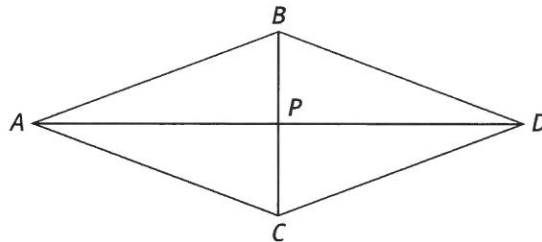

- Prove that \overline{BC} is perpendicular to \overline{AD} .

The reflection maps point A to point D ($r_\ell(A) = D$). By the definition of a reflection, this means that \overline{AD} is perpendicular to the line of reflection, which is \overline{BC} .

- Explain why $AB = BD$.

D is the image of A and reflections preserve distance, so $AB = BD$.

Lesson 9-3
Reflection

ACTIVITY 9

continued

Item 15 is related to the Perpendicular Bisector Theorem. The theorem states that if a point is on the perpendicular bisector of a segment, then it is equidistant from the endpoints of the segment. The converse is also true. If a point is equidistant from two points A and B , then it must lie on the perpendicular bisector of \overline{AB} .

Look again at quadrilateral $ABDC$. It was constructed by a reflection of a figure, which means that it has **reflectional symmetry**. Line segment BC is the **line of symmetry** of the figure. A line of symmetry can be an actual line in the figure, or it may be imaginary. A figure may have any number of lines of symmetry, including an infinite number.

15. For each figure shown below, draw all of the lines of symmetry.

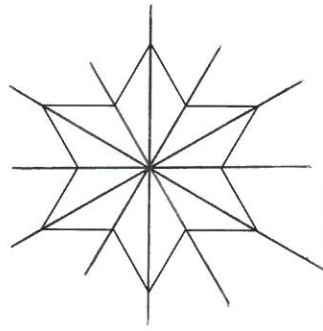
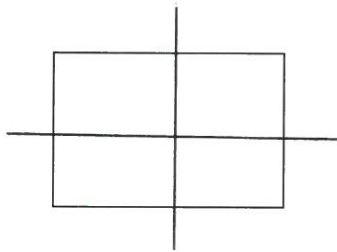

16. Triangle ABC has three lines of symmetry, labeled l_1 , l_2 , and l_3 in the figure below. What can you conclude about the triangle? Explain.

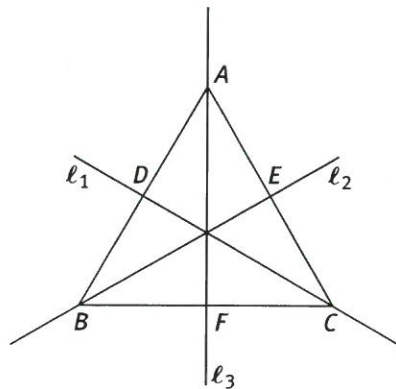

$\triangle ABC$ is equilateral.
Since reflections preserve distance, all sides must be the same length since they are images of each other under reflections across the line of symmetry.

My Notes

Check Your Understanding

17. Match the figures to their number of lines of symmetry.

rhombus

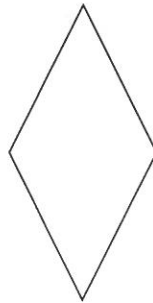

isosceles triangle

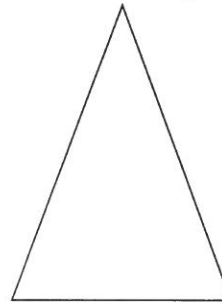

square

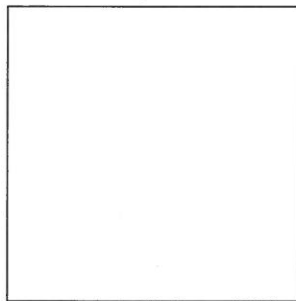

circle

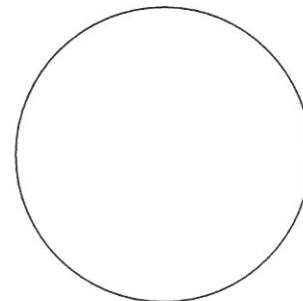

- a. one line (isosceles triangle)
- b. two lines (rhombus)
- c. four lines (square)
- d. infinitely many lines (circle)

The figure shows scalene triangle ABC , which by definition has three unequal sides. Point D is on \overline{AC} , and \overline{BD} is perpendicular to \overline{AC} .

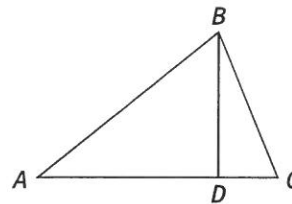

- 18. Explain why \overline{BD} is not a line of symmetry for the triangle.
- 19. Does triangle ABC have any lines of symmetry? Explain.

18) Sample: \overline{AB} is not the reflection image of \overline{CB} under a reflection across \overline{BD} .

19) No. Since the triangle is scalene, it has no lines of symmetry.

Lesson 9-3
Reflection

ACTIVITY 9

continued

LESSON 9-3 PRACTICE

Use the figure for Items 20 and 21.

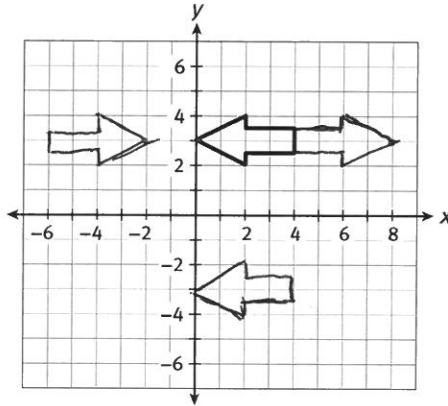

20. Draw the reflection of the arrow described by each of these functions, and identify the line of reflection.

- a. $(x, y) \rightarrow (8 - x, y)$ line of reflection: $x = 4$
- b. $(x, y) \rightarrow (-2 - x, y)$ line of reflection: $x = -1$
- c. $(x, y) \rightarrow (x, -y)$ line of reflection: $y = 0$ (x -axis)

21. **Reason abstractly.** Describe a reflection that would map the arrow onto itself.

Irregular pentagon $ABCDE$ has exactly one line of symmetry, which passes through point A .

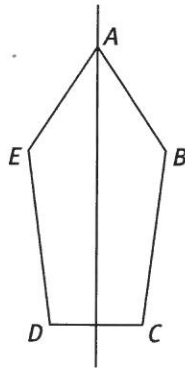

- 22. What is the image of point C under a reflection across the line of symmetry?
- 23. Does any point remain fixed under a reflection across the line of symmetry? Explain.
- 24. Which sides of the pentagon must be congruent?

My Notes

21) This is a reflection across the line of symmetry of the arrow; $y = 3$

22) Point D

23) Yes; Point A. It lies on the line of symmetry, which is the line of symmetry

24) \overline{AE} and \overline{AB} ; \overline{ED} and \overline{BC}

My Notes

Learning Objectives:

- Perform rotations on and off the coordinate plane.
- Identify and distinguish between reflectal and rotational symmetry.

SUGGESTED LEARNING STRATEGIES: Debriefing, Think-Pair-Share, Predict and Confirm, Self Revision/Peer Revision

For the big finish of the Marching Cougars performance, Mr. Scott arranges the band in a triangle formation. Then the triangle appears to rotate clockwise around a point, like a pinwheel. The center of the rotation is the vertex located at (0, 0) on the coordinate plane.

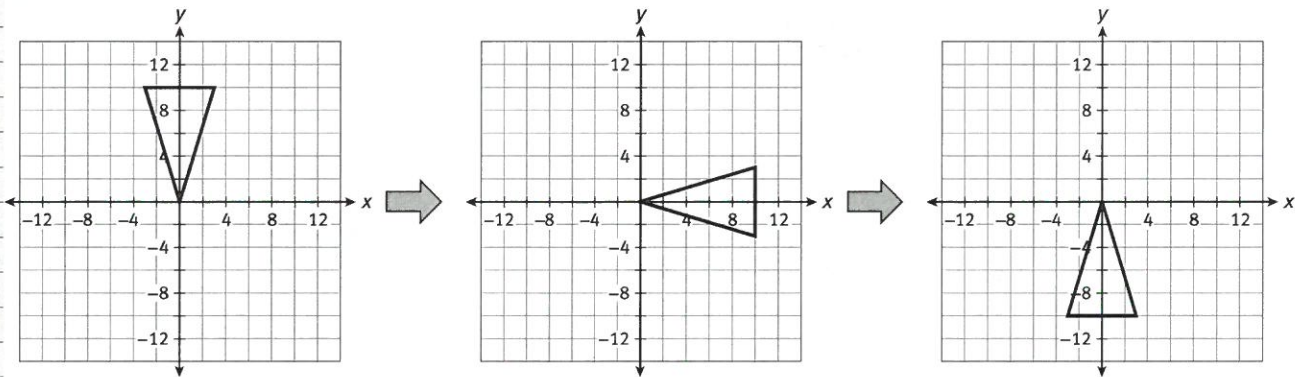

MATH TERMS

A **rotation** is a transformation that maps points across a circular arc. It preserves the distance of each point to the center of the rotation.

This spinning type of transformation is called a **rotation**. It is defined by the center of the rotation, which is mapped to itself, and the angle of the rotation.

The center of rotation may be part of the figure being rotated, as is the case shown above. Or it may be a point outside the figure.

Functions that describe rotations include $(x, y) \rightarrow (y, -x)$, which is a clockwise rotation of 90° . Repeat the function twice to produce $(x, y) \rightarrow (-x, -y)$, which is a rotation of 180° . The function $(x, y) \rightarrow (-y, x)$ is a clockwise rotation of 270° , or 90° counterclockwise.

1. Complete the table for the two rotations shown above.

Rotations around the origin

$(x, y) \rightarrow (y, -x)$ 90° cw
 $(x, y) \rightarrow (-x, -y)$ 180°
 $(x, y) \rightarrow (-y, x)$ 270° cw

Pre-image	Image $(x, y) \rightarrow (y, -x)$	Image $(x, y) \rightarrow (-x, -y)$
(3, 10)	(10, -3)	(-3, -10)
(-3, 10)	(10, 3)	(3, -10)
(0, 0)	(0, 0)	(0, 0)

Lesson 9-4
Rotations

ACTIVITY 9

continued

Use the figure for Items 2 and 3.

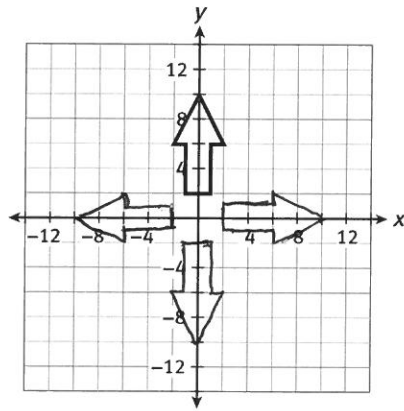

2. Predict the direction of the arrow after these rotations. The center of each rotation is $(0, 0)$.
 - a. 90 degrees clockwise *right*
 - b. 180 degrees *down*
 - c. 90 degrees counterclockwise *left*
3. Draw the three rotations. Were your predictions correct?
4. Describe the rotation that maps figure A onto figure B. (*Hint*: First identify the center of rotation.)

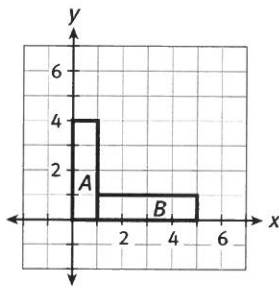

- a. a rotation of 90 degrees clockwise around the point $(1, 0)$

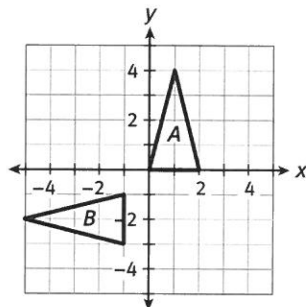

- b. a rotation of 90 degrees counterclockwise around the point $(1, -2)$

My Notes

ACTIVITY 9

continued

Lesson 9-4 Rotations

My Notes

The angle of rotation can be used to describe the image of every point of the figure. Consider the rotation shown below. Rectangle $ABCO$ is rotated 90° clockwise, and maps onto rectangle $A'B'C'O$. From the diagram, it appears that $AO \perp A'O$ and that $CO \perp C'O$. If you measure $\angle BOB'$, you will find that it, too, equals 90° .

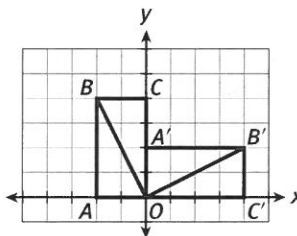

The following figure is a square that is centered around the origin O . Point A is one vertex of the square.

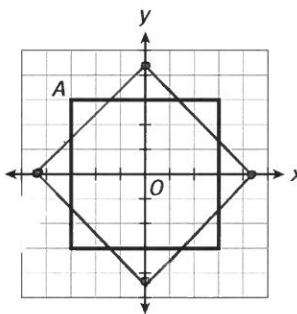

5) The intercepts on the square would be $3\sqrt{2}$ units away from the origin.

5. Draw a rotation of the square 45° clockwise about the origin. Label the point A' that is the image of point A .
6. What is the measure of $\angle AOA'$? 45°

Lesson 9-4
Rotations

ACTIVITY 9

continued

My Notes

7. **Use appropriate tools strategically.** Use geometry software to explore rotations. First, use the software to draw a quadrilateral. Then plot a point P that will serve as the center of rotation. Use the software to rotate the quadrilateral 120° counterclockwise around point P .

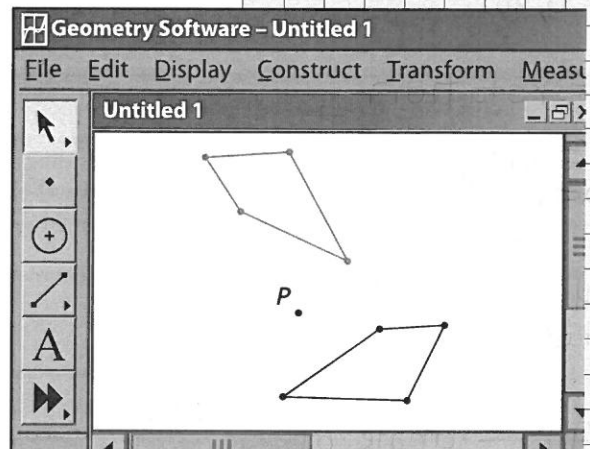
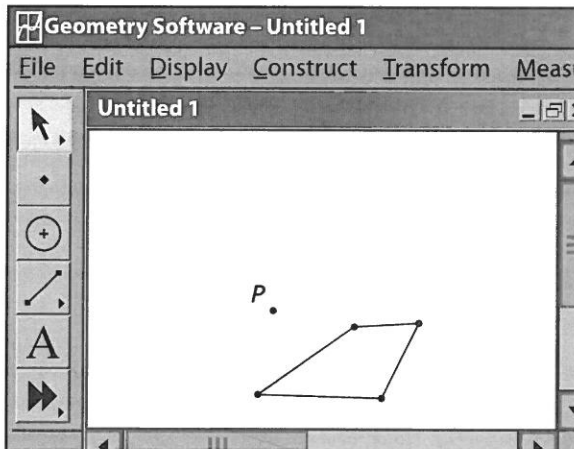

8. Choose a point of the pre-image and the corresponding point of the image. Use the software to measure the distance of each point from point P . What do you find?

Both points are the same distance from P .

9. Use the software to measure the angle formed by a point, its image, and point P , with point P as the vertex of the angle. What do you notice about this measure?

It is 120° ; the same as the angle of rotation.

10. Use the software to change the shape of the quadrilateral by dragging one or more of the points that form the quadrilateral. Do the results from Items 8 and 9 remain true no matter the shape of the quadrilateral? Explain.

Yes, a point and its image are always the same distance from P ; a point, its image, and point P form an angle of 120° when point P is the vertex of the angle.

ACTIVITY 9

continued

Lesson 9-4
Rotations

My Notes

rotation notation

$$R_{O, 90^\circ}$$

R = rotation

O = center of rotation

(the center of rotation can be anywhere)

90° = angle of rotation

NOTE: The angle of rotation that is positive produces a rotation that is counter-clockwise. A negative angle is clockwise.

Like translations and reflections, rotations can be defined independently of the coordinate plane. A **rotation** that maps P to P' and Q to Q' has the following properties. Let point O be the center of rotation.

- $PO = P'O$, and $QO = Q'O$
- $\angle POP' \cong \angle QOQ'$

To describe rotations, we will use the notation $R_{O,m^\circ}(P) = P'$, in which R_{O,m° is the function that maps point P to point P' with center of rotation at point O and through an angle of m° .

11. The diagram shows isosceles triangle ABC , and point O inside it. Draw the following rotations. Label the images of the three vertices.
- $R_{O,-90^\circ}$
 - $R_{C,90^\circ}$
 - $R_{A,90^\circ}$

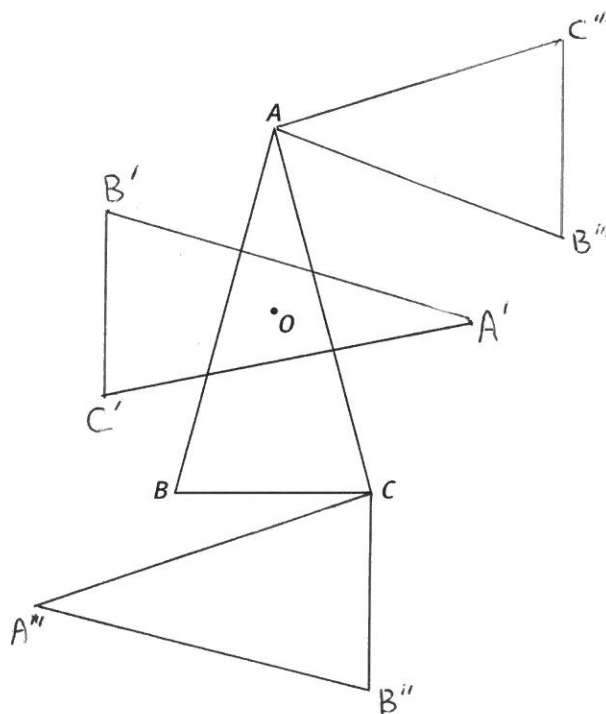

12. Describe three rotations that each map a square onto itself.

The rotations are $R_{O,90^\circ}$, $R_{O,180^\circ}$, and $R_{O,-90^\circ}$ (or $R_{O,270^\circ}$) in which O is the center of the square.

Lesson 9-4
Rotations

ACTIVITY 9

continued

Review your answer to Item 12. Figures such as squares have **rotational symmetry**, meaning that a rotation of less than 360° can map the shape onto itself. The smallest such angle is the **angle of rotational symmetry**.

13. Identify whether these figures have rotational symmetry, reflectional symmetry, or both. Also identify the angles of rotational symmetry and lines of reflectional symmetry.

- a. isosceles triangle no rotational symmetry;
one line of symmetry



- b. equilateral triangle rotational symmetry of 120° ;
three lines of symmetry

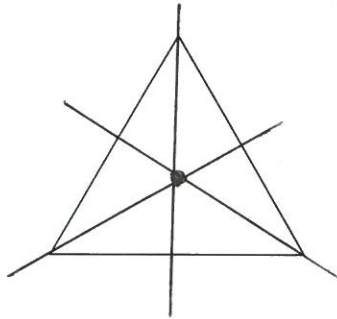

- c. rhombus rotational symmetry of 180° ;
two lines of symmetry

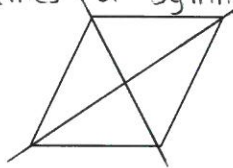

- d. regular hexagon rotational symmetry of 60° ;
three lines of symmetry

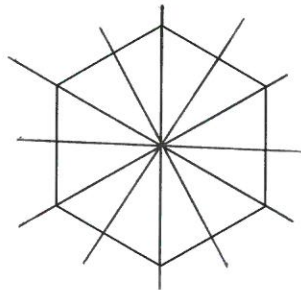

My Notes

NOTE!

An angle of rotational symmetry must be a factor of 360°

MATH TIP

Each side of a regular polygon has the same measure, and each angle has the same measure.

ACTIVITY 9

continued

Lesson 9-4
Rotations

My Notes

14a) $R_D, -90^\circ$

14c) $\angle ADA' = 90^\circ$, so
 $m\angle A'DC = 60^\circ$

- 15)
- square
 - regular pentagon
 - rhombus
 - shape of the letter S

- 16)
- 90° clockwise about $(4, 3)$
 - 90° counterclockwise about $(0, 3)$
 - 90° clockwise about $(0, 0)$

- 17)
- downward; tip at $(-4, 1)$
 - to the right, tip at $(4, 3)$
 - upward, tip at $(5, 2)$

18) a regular 36-sided polygon

19) No; 37 is not a factor of 360.

Check Your Understanding

14. The figure shows parallelogram $ABCD$ (shaded) and its rotation.

- Name the rotation.
- Label the vertices A' , B' , and C' of the rotated figure.
- If $\angle ADC = 30^\circ$, find $\angle A'DC$.

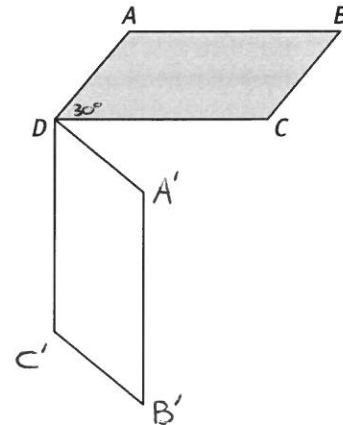

15. Identify an example of a figure that meets these sets of properties.
- rotational symmetry with angle of rotational symmetry of 90°
 - rotational symmetry with angles of rotational symmetry of 72°
 - rotational symmetry with angle of rotational symmetry of 180° , two lines of reflectional symmetry
 - rotational symmetry with angle of rotational symmetry of 180° , no lines of reflectional symmetry

LESSON 9-4 PRACTICE

16. Describe the rotation that would move the arrow to these positions.

- pointing up, with the tip at $(4, 7)$
- pointing down, with the tip at $(0, 3)$
- pointing up, with the tip at $(3, 0)$

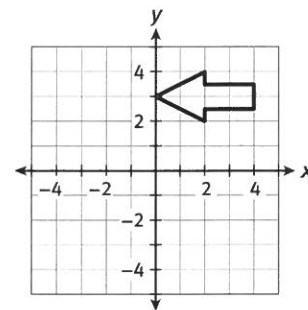

17. Identify the direction of the arrow and the position of the tip after these rotations.

- 90° counterclockwise about $(4, 3)$
- 180° about $(2, 3)$
- 90° clockwise about $(2, 0)$

18. Describe a figure that has an angle of rotational symmetry of 10° .

19. **Construct viable arguments.** Do you think it is possible for a figure to have an angle of rotational symmetry of 37° ? If so, describe the figure. If not, explain why not.